

Free-Standing Terminal Housing



Terminal

The **free-standing housings TERMINAL** serve as a platform for diverse applications and individual system solutions, for example:

- **entry and exit control systems**
- **intercommunication systems**
- **locking systems**

The modular housing largely consists of aluminium, while the base area is made of powder-coated stainless steel. This ensures the best possible protection against corrosion.

The front of the free-standing housing consists of a removable door and a front panel that can be pulled out on telescopic rails. This allows optimal accessibility for maintenance and service. The installation position and the number of devices can be defined individually inside the front panel. An optional connection panel that is mounted in the housing behind the removable door is available for electrical connections.

The free-standing housing TERMINAL is available in five different sizes:

Car traffic:

The versions MS and MH differ in the height of the front panel while maintaining the same overall height.

The MXL model differs in the housing width from the MH model.

Car/truck traffic:

The ML version is almost twice as high. It is equipped with two removable doors and two pull-out front panels for the integration of separate access control systems for cars and trucks at the appropriate vehicle height.

The MXXL version differs from the ML type in height and a considerably wider housing as well as a one-piece, full-length and extendable front.

Three standard colours are available: orange (**RAL 2000**), white aluminium (**RAL 9006**) and grey aluminium (**RAL 9007**). On request, the TERMINAL free-standing housings are available in all RAL colours at an extra charge.

Terminal

Attributes:

- free-standing operating and communication units
- Convenient access solution for unmanned entrances and access routes
- air-conditionable terminal room for on-site access and communication solutions
- timeless, elegant design
- numerous options possible

Used for authentication at automated entrances and approaches, especially in areas requiring control and protection:

- authority facilities
- industrial plants and power plants
- military facilities
- supply facilities
- airports (operating areas)
- commercial properties
- parking space management

Data:

Technical specifications	Terminal-MS	Terminal-MH	Terminal-ML	Terminal-MXL	Terminal-MXXL
Use:	car	car	car/ truck	car/ van	car/ truck
Dimensions housing (WxHxD)	296x1202x266	296x1202x266	296x2202x266	497x367x1495	497x367x2795
Installation area [mm]	209x337	209x487	2x209x337	310x705	310x1240 and 310x705
Front panel version	pull-out (telescopic slides)				
Housing version	powder-coated aluminium				
Base area	stainless steel, powder-coated				
Weight without fittings [kg]	15	15	27	56	92
Protection class housing	IP54				
Accessories	Connection panel, optional heating, socket outlet				

Terminal

Types slim:



ML



MS



MH

Terminal

Types large:



MXXL

MXL

Terminal

Installation dimensions Terminal MS and ML:

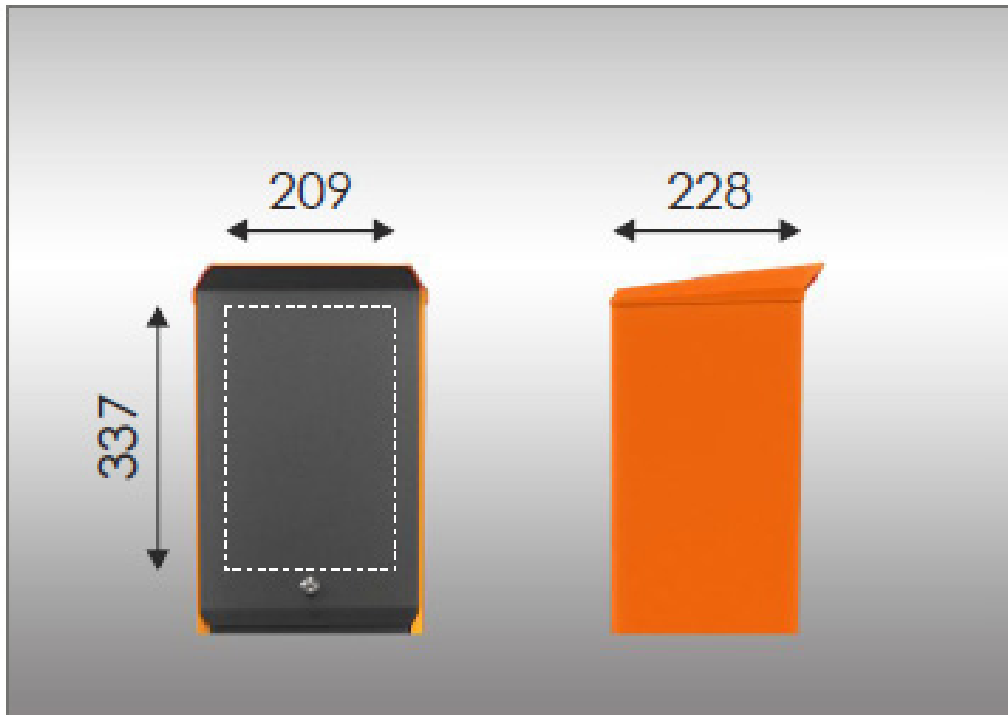

Installation dimensions Terminal MH:

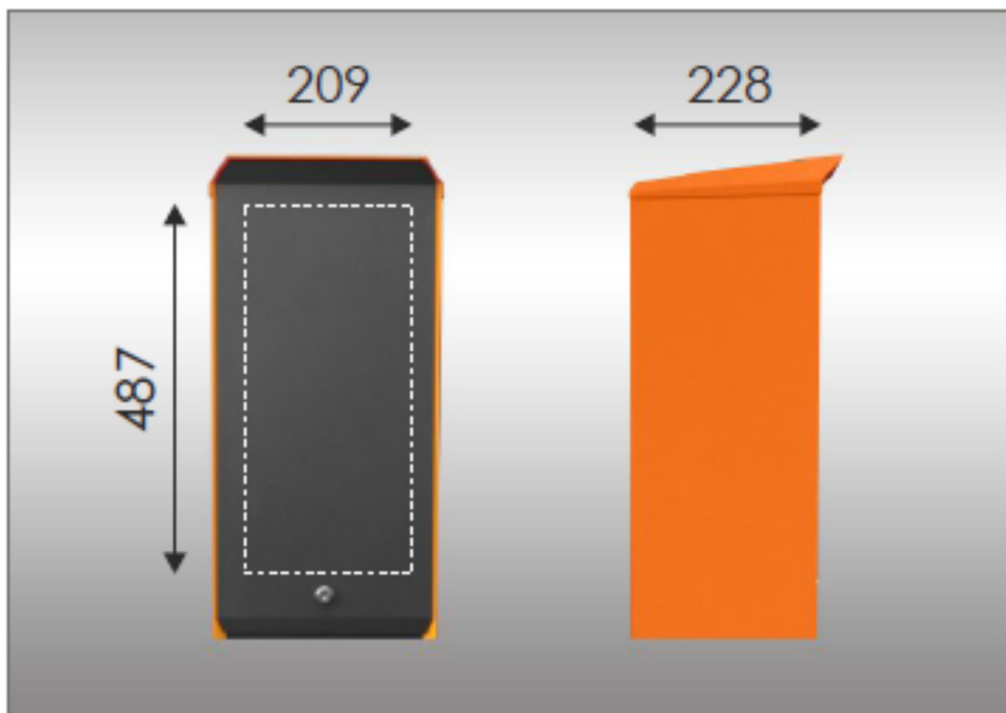

Terminal

Installation dimensions Terminal MXL and MXXL:

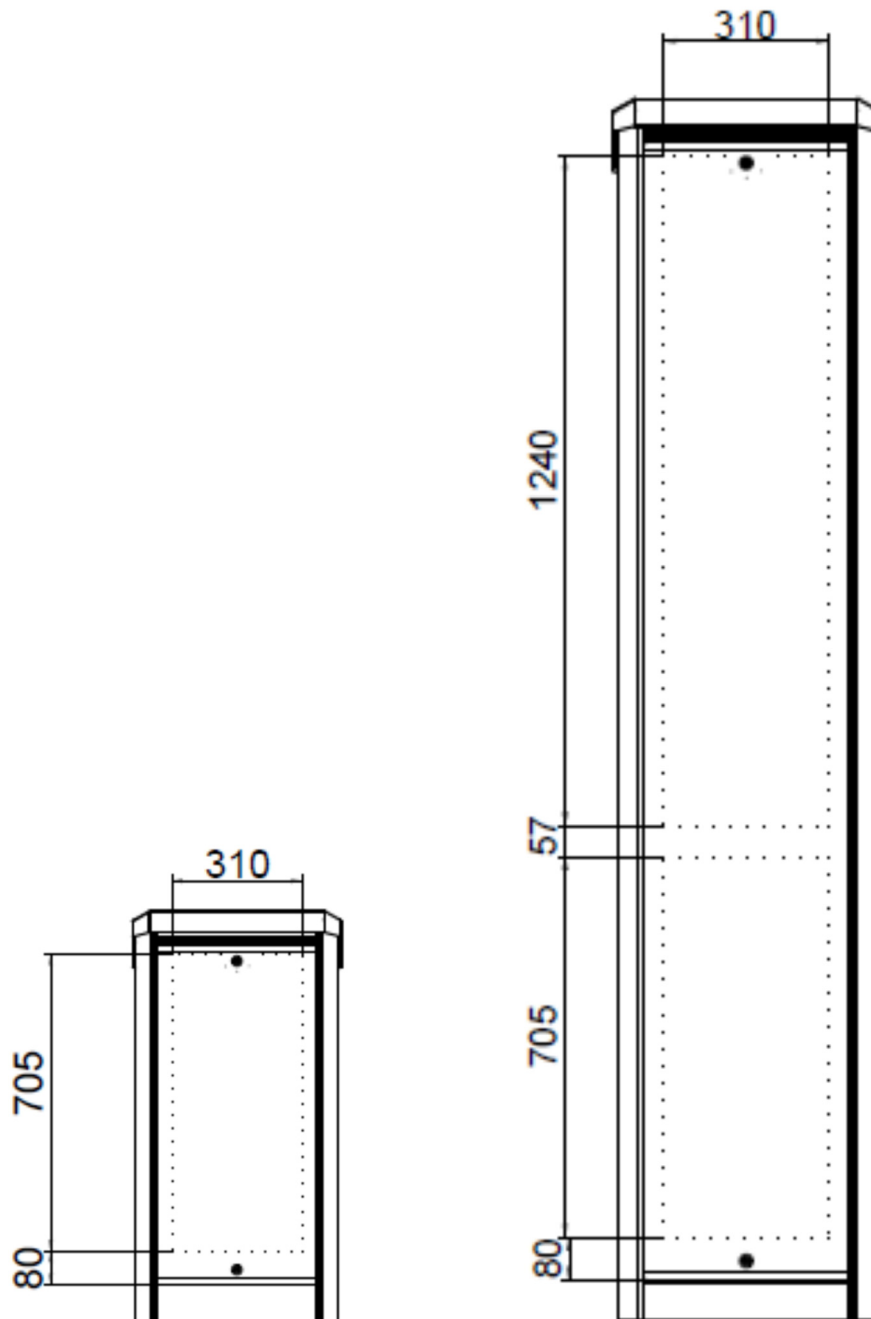

Terminal

